



# PRODUCT INSTALLATION GUIDE



<b>PRODUCT:</b>	<i>Right Hand - Dash Switch Panel (Cupholder/Card Holder replacement)</i>
<b>VEHICLE:</b>	<i>Ford Next Gen Models</i>
<b>PRODUCT NO.</b>	<i>OTA-NXT_Gen-SP-01</i>

## TOOLS REQUIRED:

- 7mm SOCKET
- SOCKET WRENCH
- SOCKET HANDLE SPINNER OR SOCKET EXTENSION
- PLASTIC TRIM REMOVAL TOOL

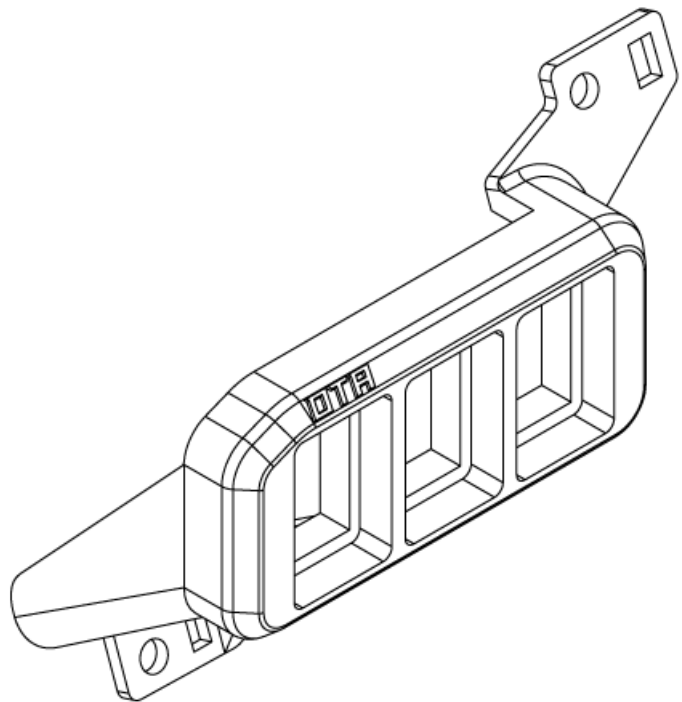

<b>DESCRIPTION</b>	<b>QTY</b>	<b>PART NUMBER</b>
RH Next Gen Ranger Switch Panel	1	OTA-NXT-Gen-SP-01

# OVERLAND TOURERS AUSTRALIA

---

## STEP 01:

PULL AND REMOVE THE DOOR SEAL/TRIM OFF NEAR THE SIDE PANEL.



## STEP 02:

USING THE PLASTIC TRIM TOOL, CAREFULLY REMOVE THE PANEL, WORKING YOUR WAY ALONG THE FRONT EDGE UNTIL ALL CLIPS ARE REMOVED.



*STEP 03:*

WITH THE PANEL REMOVED - USE THE SOCKET WRENCH AND 7mm SOCKET TO REMOVE THE SINGLE BOLT.

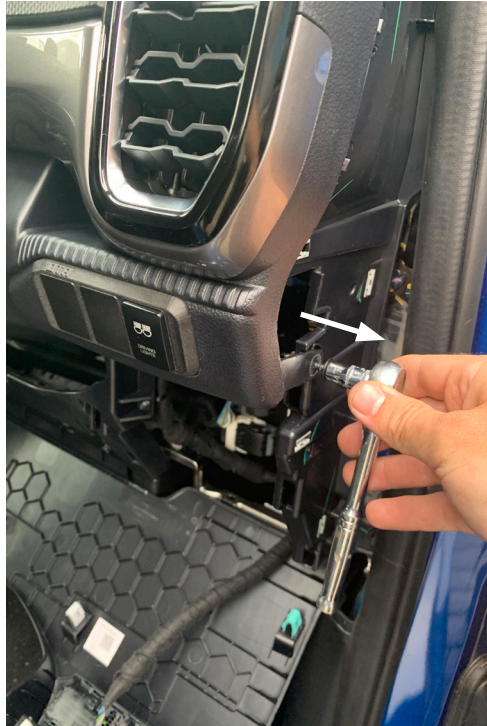

*STEP 04:*

USING BOTH HANDS, GRAB THE LEFT AND RIGHT SIDE OF THE BOTTOM PANEL AND CAREFULLY UNCLIP THE PANEL FROM THE TOP END DOWN.



**STEP 05:**

FIRSTLY, USING TWO FINGERS DISENGAGE THE TWO CLIPS CIRCLED IN RED, THEN USING THE TRIM CLIP REMOVER, CAREFULLY WORK YOUR WAY ALONG THE EDGE OF THE TOP PANEL TO UNCLIP IT. YOU CAN EITHER FULLY REMOVE THE PANEL, OR UNCLIP THE BOTTOM ENOUGH TO GAIN ACCESS TO THE CUP-HOLDER/CARD-HOLDER. NOTE THAT THE MIDDLE SECTION ABOVE THE STEERING WHEEL IS SEPARATE TO THIS PIECE.



**STEP 06:**

USING THE 7mm SOCKET AND SOCKET HANDLE SPINNER, REMOVE THE TWO BOLTS FIXING THE CUP-HOLDER/CARD-HOLDER IN PLACE. ONCE THE TWO BOLTS ARE REMOVED, YOU WILL NEED TO PULL THE COMPONENT OUT, BEING CAREFUL OF THE CLIP ON THE BACK OF IT



**STEP 07:**

WITH THE CUPHOLDER/CARD-HOLDER REMOVED - REPLACE WITH THE OTA SWITCH PANEL, FIXING IT BACK IN PLACE USING THE SAME BOLTS AND MOUNTING POINTS. (ENSURE YOUR SWITCHES ARE INSERTED INTO THE PANEL AND WIRING HARNESSES ARE PREPARED BEFORE COMPLETING THE NEXT STEP)



**STEP 08:**

ONCE YOUR PANEL IS PREPARED AND FULLY INSTALLED, CLIP THE TOP THEN BOTTOM PANEL BACK IN PLACE, AND FIX THE BOLT BACK INTO THE TAB ON THE RIGHT HAND SIDE.



**STEP 09:**

**WITH THE TWO FRONT PANELS REINSTALLED, CLIP THE SIDE PANEL BACK IN PLACE AND REFIT THE DOOR SEAL, ENSURING IT IS ALL BACK IN CORRECTLY.**

**YOUR OTA SWITCH PANEL IS NOW INSTALLED!**

